

CH
Cooper & Hunter



VITAL INVERTER“ yra naujos kartos patikimas oro kondicionierius minimalistiniu baltu korpusu ir ekologišku šaltnešiu R32.



SERIES

VITAL INVERTER

Series VITAL INVERTER



FUNKCIJOS

HEALTH						COMFORT MANAGEMENT								
Mode SLEEP	Technology CH 7-SKY	ECO-FRESH	CH SMART-ION filters	Double Self-clean	Self-clean	Locking the remote control	Timer	LED display	Turbo mode	Multi speed fan	SWING Mode	Dehumidification mode	Wi-Fi	I FEEL

INTELLIGENT CONTROL			TECHNOLOGICAL						ENERGY EFFICIENCY		
Anti Freeze protection	Auto restart	Self diagnostics	R32 Refrigerant	Silent mode	Auto protection	Function +8 °C	Technology I-Action	Coating BLUE-FIN	Warm start	Energy Efficiency	Generation 6

MODELIS		CH-S07FTXF2-NG	CH-S09FTXF2-NG	CH-S12FTXF2-NG	CH-S18FTXF2-NG	CH-S24FTXF2-NG
Galia	Vėsinimas	kW 2.35 (0.37-2.53)	2.70 (0.50-3.35)	3.20 (0.60-3.60)	4.60 (0.65-5.20)	6.20 (1.80-6.90)
	Šildymas	kW 2.50 (0.51-2.60)	2.80 (0.50-3.30)	3.40 (0.60-3.80)	5.20 (0.70-5.40)	6.50 (1.30-7.03)
Suvartojama energija	Vėsinimas	kW 0.68 (0.16-0.95)	0.73 (0.20-1.50)	0.99 (0.16-1.40)	1.35 (0.16-1.70)	1.82 (0.45-2.20)
	Šildymas	kW 0.65 (0.20-1.00)	0.68 (0.16-1.40)	0.92 (0.20-1.50)	1.34 (0.20-1.60)	1.91 (0.45-2.30)
Energetinis efektyvumas	Vėsinimas (SEER*)	kW/kW 5.1 (A)	6.8 (A++)	6.1 (A++)	6.4 (A++)	6.8 (A++)
	Šildymas (SCOP**)	kW/kW 3.8 (A)	4.2 (A+)	4.0 (A+)	4.0 (A+)	4.0 (A+)

* SEER - sezoninis energetinio efektyvumo koeficientas vėsinant
 ** SCOP - sezoninis energetinio efektyvumo koeficientas šildant

VIDINĖ DALIS		CH-S07FTXF2-NG	CH-S09FTXF2-NG	CH-S12FTXF2-NG	CH-S18FTXF2-NG	CH-S24FTXF2-NG
Oro srautas	m³/h	300/390/420/500	280/310/340/400/480/520/550	280/320/350/400/480/520/590	600/700/800/850	400/600/800/900
Garso slėgio lygis	dB (A)	27/33/38/40	21/26/29/33/35/37/40	24/26/30/33/35/37/41	31/38/42/44	30/37/45/48
Kondensato kiekis	l/h	0.6	0.8	1.4	1.8	1.8
Svoris	kg	8.2	8.5	8.0	13.5	13

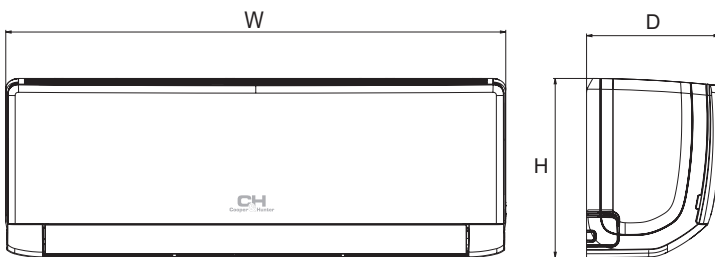

MODELIS	W (mm)	H (mm)	D (mm)
CH-S07FTXF2-NG	713	270	195
CH-S09FTXF2-NG	773	250	185
CH-S12FTXF2-NG	773	250	185
CH-S18FTXF2-NG	970	300	225
CH-S24FTXF2-NG	970	300	225

LAUKO DALIS		CH-S07FTXF2-NG	CH-S09FTXF2-NG	CH-S12FTXF2-NG	CH-S18FTXF2-NG	CH-S24FTXF2-NG
Garso slėgio lygis	dB (A)	51	51	52	55	57
Kompresoriaus tipas		Rotary				
Šaltnešio tipas		R32				
Darbinės lauko temperatūros ribos vėsinant	°C	-15 ... +43				
Darbinės lauko temperatūros ribos šildant	°C	-15 ... +24				
Maitinimo šaltinis		~220-240V/50Hz/1 Ph				
Svoris	kg	20.8	24.5	25	26.5	36.5
Šaltnešio kiekis	kg	0.45	0.50	0.55	0.75	1.23
Skysčio linijos skersmuo	mm/inch	6.35/1/4"	6.35/1/4"	6.35/1/4"	6.35/1/4"	6.35/1/4"
Dujų linijos skersmuo	mm/inch	9.52/3/8"	9.52/3/8"	9.52/3/8"	9.52/3/8"	12.7/1/2"
Maksimalus vamzdžio aukčio perkrytis	m	10	10	10	10	10
Maksimalus vamzdžio ilgis	m	15	15	20	25	25

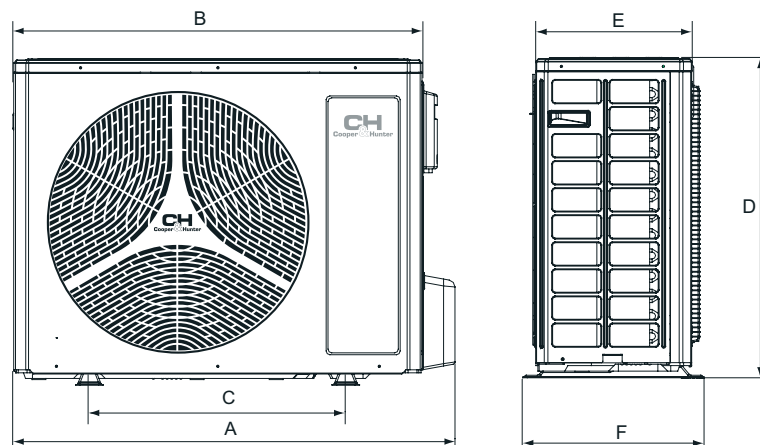

MODELIS	A (mm)	B (mm)	C (mm)	D (mm)	E (mm)	F (mm)
CH-S07FTXF2-NG	710	650	430	450	244	293
CH-S09FTXF2-NG	732	675	455	555	285	330
CH-S12FTXF2-NG	732	675	455	555	285	330
CH-S18FTXF2-NG	732	675	455	555	285	330
CH-S24FTXF2-NG	873	805	528	555	317	376