

CH
Cooper & Hunter

SERIES

STILIUS IR
PATIKIMUMAS

ARCTICUS



SERIES ARCTIC NG



5 YEARS +50°C -25°C 20dB

CE RoHS **INVERTER**



FUNKCIJOS

HEALTH						COMFORT MANAGEMENT								
Mode SLEEP	Technology CH 7-SKY	ECO-FRESH	CH SMART-ION filter	Double Self-clean	Self-clean	Locking the remote control	Timer	LED display	Turbo mode	Multi speed fan	Dehumidification mode	Dehumidification mode	Wi-Fi	I FEEL

INTELLIGENT CONTROL				TECHNOLOGICAL						ENERGY EFFICIENCY			
Anti Freeze protection	Auto restart	Self diagnostics	Display backlight	Wired controller connection	R32 Refrigerant	Silent mode	Auto protection	Function 8°C	Technology I-Action	Coating BLUE-FIN	Warm start	Energy Efficiency	Generation 6

VALDIKLIAI IR PRIEDAI (OPCIJA)



Wired Controller
XK76



Wired Controller
CE50-24/E

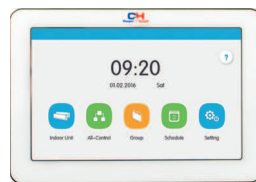

Wired Controller
CE52-24/F

MODELIS		CH-S09FTXLA2-NG	CH-S12FTXLA2-NG	CH-S18FTXLA2-NG	CH-S24FTXLA2-NG	
Galia	Vėsinimas	kW	2.70 (0.80-3.80)	3.51 (0.90-4.40)	5.20 (1.00-6.10)	7.10 (2.00-8.85)
	Šildymas	kW	3.00 (0.90-4.25)	3.81 (0.90-4.70)	5.60 (1.10-6.60)	7.80 (1.80-9.45)
Suvartojama energija	Vėsinimas	kW	0.69 (0.10-1.30)	0.96 (0.22-1.40)	1.58 (0.10-2.35)	2.03 (0.45-2.90)
	Šildymas	kW	0.70 (0.15-1.40)	0.95 (0.22-1.55)	1.44 (0.18-2.40)	2.00 (0.35-3.00)
Energetinis efektyvumas	Vėsinimas (SEER*)	kW/kW	7.5 (A++)	7.1 (A++)	7.1 (A++)	7.0 (A++)
	Šildymas (SCOP**)	kW/kW	5.3 (A+++)	5.2 (A+++)	5.7 (A+++)	5.4 (A+++)

* SEER - sezoninis energetinio efektyvumo koeficientas vėsinant.

** SCOP - sezoninis energetinio efektyvumo koeficientas šildant.

VIDINĖ DALIS		CH-S09FTXLA2-NG	CH-S12FTXLA2-NG	CH-S18FTXLA2-NG	CH-S24FTXLA2-NG
Oro srautas	m ³ /h	390/420/440/470/540/570/610	360/420/480/540/600/650/700	460/520/570/610/680/750/850	800/850/900/950/1000/1100/1250
Garso slėgio lygis	dB (A)	20/22/24/26/28/32/37	21/23/24/26/29/33/38	24/27/31/33/38/41/45	27/29/35/37/39/42/47
Kondensato kiekis	l/h	1.69	1.40	1.9	2.4
Svoris	kg	10.5	10.5	13	16.5

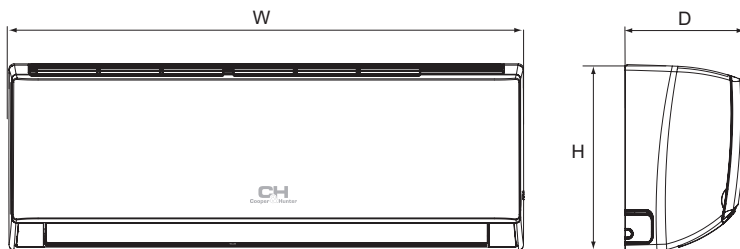

MODELIS	W (mm)	H (mm)	D (mm)
CH-S09FTXLA2-NG	845	289	209
CH-S12FTXLA2-NG	845	289	209
CH-S18FTXLA2-NG	970	300	224
CH-S24FTXLA2-NG	1078	325	246

LAUKO DALIS		CH-S09FTXLA2-NG	CH-S12FTXLA2-NG	CH-S18FTXLA2-NG	CH-S24FTXLA2-NG
Garso slėgio lygis	dB (A)	50	52	56	59
Kompresoriaus tipas		Rotary			
Šaltnešio tipas		R32			
Darbinės lauko temperatūros ribos vėsinant	°C	-15 ... +50			
Darbinės lauko temperatūros ribos šildant	°C	-25 ... +30			
Maitinimo šaltinis		~220-240V/50Hz/1 Ph			
Svoris	kg	24.5	24.5	30.5	41.5
Šaltnešio kiekis	kg	0.53	0.57	0.82	1.50
Skysčio linijos skersmuo	mm/inch	6.35/1/4"	6.35/1/4"	6.35/1/4"	6.35/1/4"
Dujų linijos skersmuo	mm/inch	9.52/3/8"	9.52/3/8"	12.7/1/2"	15.88/5/8"
Maksimalus vamzdžio aukščio perkrytis	m	10	10	10	10
Maksimalus vamzdžio ilgis	m	15	15	25	25

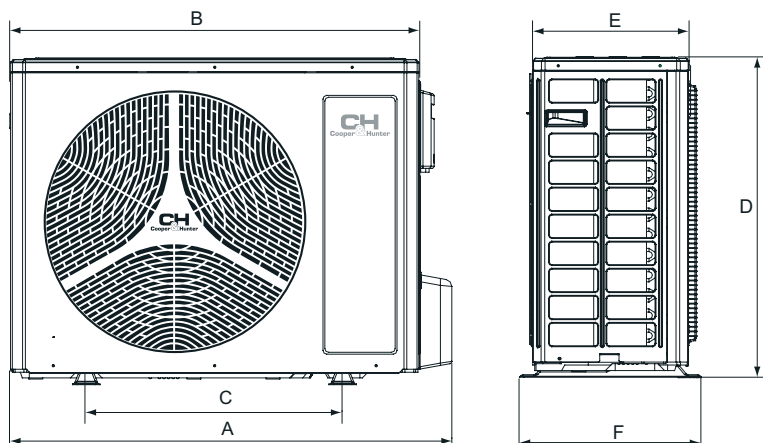

MODELIS	A (mm)	B (mm)	C (mm)	D (mm)	E (mm)	F (mm)
CH-S09FTXLA2-NG	732	675	455	555	285	330
CH-S12FTXLA2-NG	732	675	455	555	285	330
CH-S18FTXLA2-NG	802	745	513	555	300	350
CH-S24FTXLA2-NG	958	889	570	660	340	402