

CH
Cooper & Hunter

SERIES

Inverter Console NG serija – novatoriškas ir kompaktiškas įrenginys, kurį galima montuoti ant grindų arba ant sienos ir puikiai tinka po langų. Įrenginys turi galimybę orą tiekti per viršutines groteles arba per viršutines ir apatines groteles kartu.



INVERTER
CONSOLE
NG

Series

INVERTER CONSOLE NG

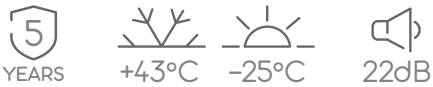

INVERTER

CE RoHS

FUNKCIJOS

HEALTH

COMFORT MANAGEMENT



Mode SLEEP



ECO-FRESH



CH SMART-ION Filter



Self-clean



Locking the remote control



Timer



LED display



Turbo mode



Multi speed fan



SWING mode



Dehumidification mode



Wi-Fi



I FEEL

INTELLIGENT CONTROL

TECHNOLOGICAL

ENERGY EFFICIENCY



Anti Freeze protection



Auto restart



Self diagnostics



Wired controller connection



R32 Refrigerant



Silent mode



Auto protection



Function +8 °C



Technology I-Action



Coating BLUE-FIN



Warm start



Energy Efficiency A++



Generation 6

VALDIKLIAI IR PRIEDAI (OPCIJA)



Wired Controller
XK76



Wired Controller
CES0-24/E



Wired Controller
CES2-24/F

MODELIS			CH-S09FVX2-NG	CH-S12FVX2-NG	CH-S18FVX2-NG
Galia	Vėsinimas	kW	2.70 (0.70-3.40)	3.52 (0.80-4.40)	5.20 (1.26-6.60)
	Šildymas	kW	2.90 (0.60-3.50)	3.80 (1.10-4.40)	5.33 (1.12-6.68)
Suvartjama energija	Vėsinimas	kW	0.70 (0.17-1.30)	0.93 (0.16-1.50)	1.45 (0.38-2.45)
	Šildymas	kW	0.73 (0.13-1.35)	0.96 (0.17-1.50)	1.55 (0.35-2.50)
Energetinis efektyvumas	Vėsinimas (SEER*)	kW/kW	7.2 (A++)	7.0 (A++)	6.6 (A++)
	Šildymas (SCOP**)	kW/kW	5.3 (A+++)	5.3 (A+++)	5.1 (A+++)

* SEER - sezoninis energetinio efektyvumo koeficientas vėsinant.

** SCOP - sezoninis energetinio efektyvumo koeficientas šildant.

VIDINĖ DALIS		CH-S09FVX2-NG	CH-S12FVX2-NG	CH-S18FVX2-NG
Oro srautas	m ³ /h	250/280/330/370/410/430/500	280/360/400/440/480/520/600	320/410/460/520/580/650/700
Garso slėgio lygis	dB (A)	22/25/28/30/32/36/38	24/29/33/36/38/40/44	32/37/40/42/45/47/49
Kondensato kiekis	l/h	0.8	1.2	1.8
Svoris	kg	15.5	16	16

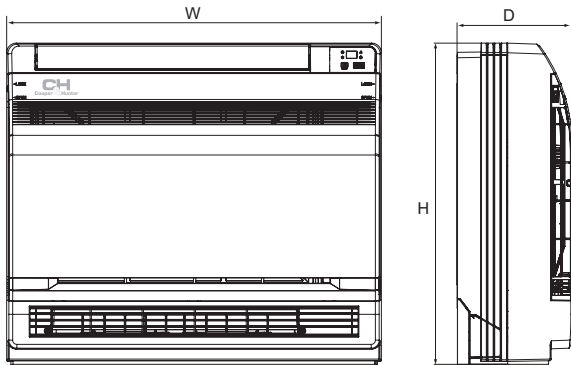

MODELIS	W (mm)	H (mm)	D (mm)
CH-S09FVX2-NG	700	600	215
CH-S12FVX2-NG	700	600	215
CH-S18FVX2-NG	700	600	215

LAUKO DALIS		CH-S09FVX2-NG	CH-S12FVX2-NG	CH-S18FVX2-NG
Garso slėgio lygis	dB (A)	51	53	59
Kompresoriaus tipas			Rotary	
Šaltnešio tipas			R32	
Darbinės lauko temperatūros ribos vėsinant	°C		-15 ... +43	
Darbinės lauko temperatūros ribos šildant	°C		-25 ... +24	
Maitinimas			~220-240V/50Hz/1 Ph	
Svoris	kg	24.0	27.5	41
Šaltnešio kiekis	kg	0.51	0.75	1.00
Skysčio linijos skersmuo	mm/inch	6.35/1/4"	6.35/1/4"	6.35/1/4"
Dujų linijos skersmuo	mm/inch	9.52/3/8"	9.52/3/8"	12.7/1/2"
Maksimalus vamzdžio aukščio perkrytis	m	10	10	10
Maksimalus vamzdžio ilgis	m	15	20	25

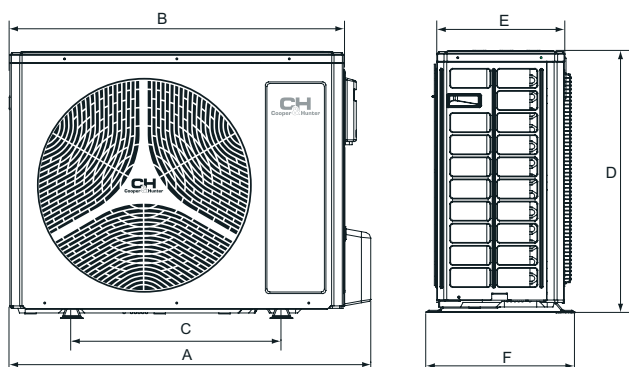

MODELIS	A (mm)	B (mm)	C (mm)	D (mm)	E (mm)	F (mm)
CH-S09FVX2-NG	732	675	455	555	285	330
CH-S12FVX2-NG	802	745	512	555	300	350
CH-S18FVX2-NG	958	889	570	660	340	402